

12M26.3 +SCR

Propulsion Diesel Engine

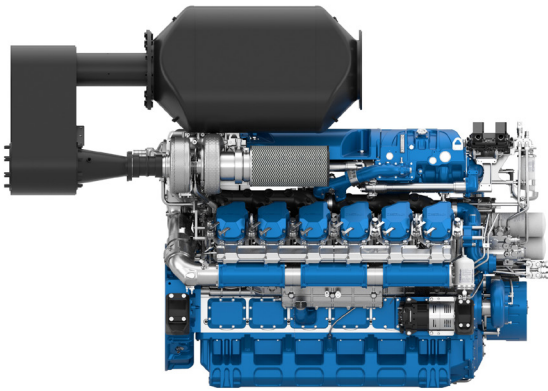

Number of cylinders	12V @ 90
Bore and stroke (mm)	150 X 150
Total displacement (L)	31.8
Compression ratio	15/1
Engine rotation	counter clockwise
Idle speed	650
Flywheel	SAE 0
Flywheel housing	SAE 18"

Customer benefits

Most advanced Common Rail technology and high-end injection system (2200 bar), key to achieve strict emissions regulations and competitive performances.

Highly efficient turbochargers optimized to operate with high performance keeping fuel consumption under control.

Individual cylinder heads allowing easy maintenance.

Key components made of highly reliable materials.

Rated power - Fuel consumption

Duty	kW	HP	RPM	Fuel consumption			IMO	EPA	CCNR	CE97/68
				Optimum value	Rated power					
				g/kWh	g/kWh	l/h				
P1	883	1200	1800	200	202	209	II/III	3/4	II	III A
P2	1030	1400	2100	201	210	254	II/III	3/4	II	III A
P2	1103	1500	2200	200	210	275	II/III	3/4	II	
P3	1214	1650	2300	201	209	311	II/III	3/4	-	-

	P1	P2	P3
Application	Unrestricted Continuous	Heavy	Intermittent
Engine load variations	Very Little To None	Continuous	Important
Average Engine load factor	80-100%	30-80%	50%
Annual working time	More Than 5000 H	3000 -5000 H	1000 - 3000 H
Time at full load	Unlimited	8h Each 12h	2h Each 12h

P1 Continuous Duty

- Deep sea trawlers
- Shrimps trawlers
- Sea going tug boats
- River tug boats
- Push boats
- Freighters
- Dredges
- LCT
- Ferries

P2 Heavy Duty

- Deep sea trawlers
- Shrimps trawlers
- Sea going tug boats
- River tug boats
- Push boats
- Freighters
- Dredges
- LCT
- Ferries

P3 Intermittent Duty

- Seasonal passenger vessels
- Fishing boats
- Pilot boats
- Commercial pleasure boats
- Pump boats
- Displacement sailboats
- Trawlers
- Bow thrusters

P4 Light Duty

- Private pleasure boats
- Multi-hull pleasure boats
- Survey or rescue fast vessels
- Military fast vessels.

P5 High performance Duty

- Private pleasure boats
- Multi-hull pleasure boats

Dimensions and dry weight (mm/kg)

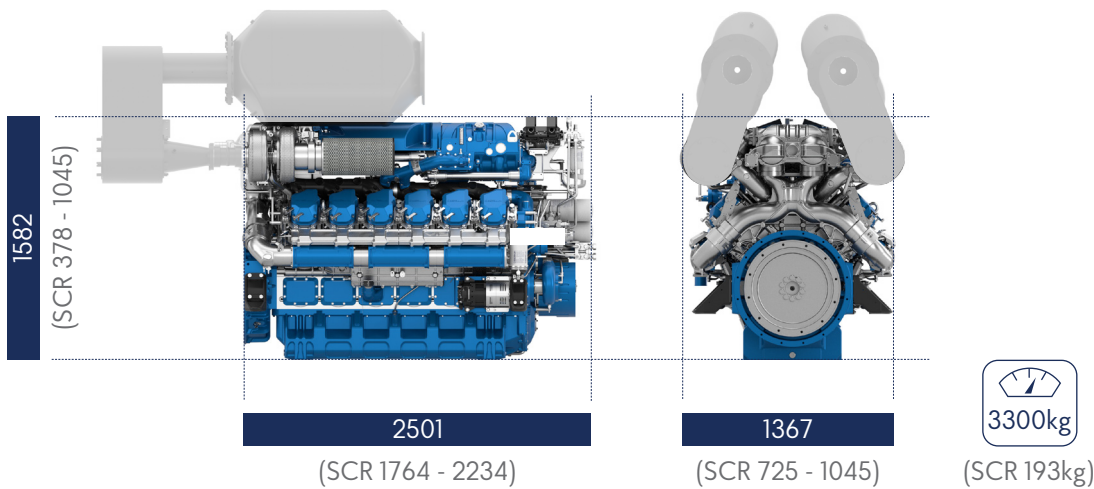

Standard equipment

Cooling System

Two - stage cooling circuit with built - in HT thermostatic valve
Integrated fresh water expansion tank
High efficiency tubular heat exchanger
Gear driven centrifugal raw water pump
Self priming raw water pump with bronze impeller

Lubrication System

Full flow lube oil filters duplex type
Fresh water cooled lube oil heat exchanger

Fuel System

Common-rail electronic injection
High pressure pump with shielded high pressure injection rail and pipes
Fuel oil filter duplex type
External fuel pre-filter with water separator

Intake Air and Exhaust System

Double flow raw water cooled intake air heat exchanger module
High efficiency dry turbocharger with ball bearing technology
Two Stage Turbocharging system

Electrical System

Voltage: 24V DC insulated
Electrical starter
190A battery alternator

Optional Equipment

Wet exhaust
PTO elastic coupling
Additional pulley
Electric drain system
Standard PTO for hydraulic pump
Different alternators possible - including 12V
Electrical rotary actuator

Power Curves

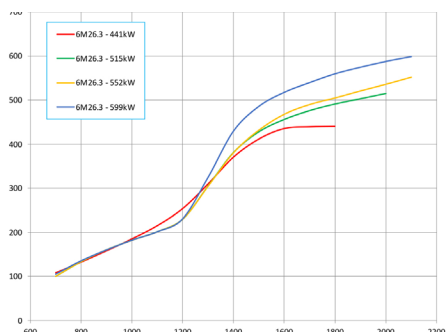

Torque Curves

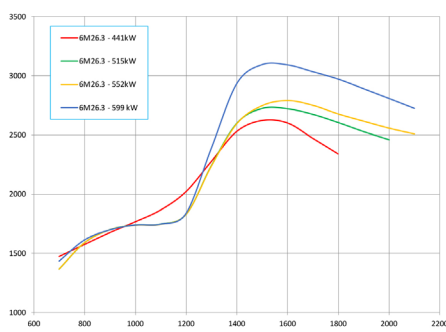

Cons. Urea - Full Curve

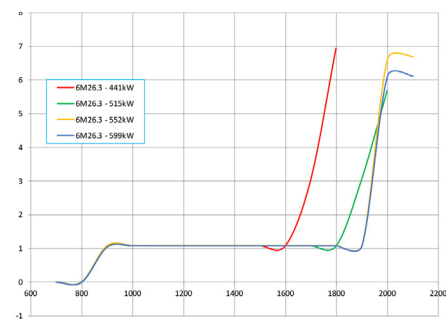

Full Load

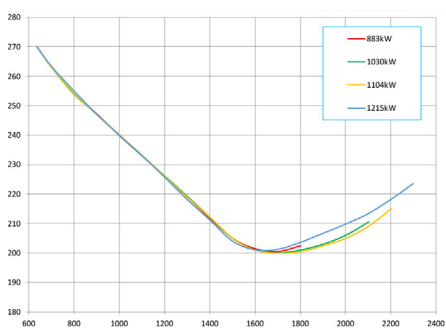

Prop Curves

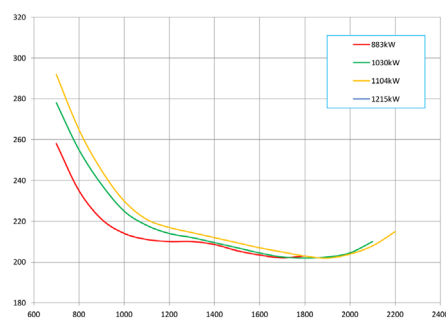

Power definition

(Standard ISO 3046/1 - 1995 (F))

Reference conditions

Ambient temperature	25°C / 77°F
Barometric pressure	100 kPa
Relative humidity	30%R
Raw water temperature	25°C / 77°F

Fuel oil

Relative density	0,840 ± 0,005
Lower calorific power	42 700 kJ/kg
Consumption tolerances	+ 5%
	(DIN ISO 3046-1)
Inlet limit temperature	35°C / 95°F

Our ratings also comply with classification societies maximum temperature definition without power derating.

Ambient temperature	45°C / 113°F
Raw water temperature	32°C / 90°F