

# 12M26.3 STAGE V

Propulsion Diesel Engine

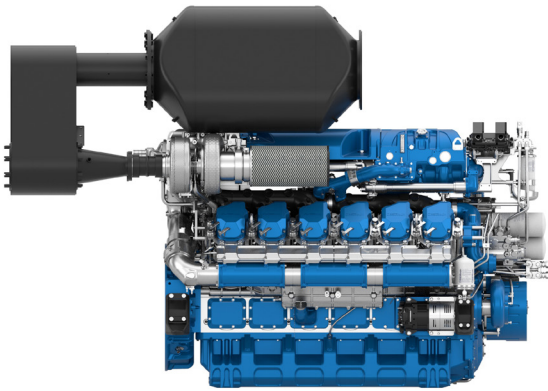

Number of cylinders	12V @ 90
Bore and stroke (mm)	150 X 150
Total displacement (L)	31.8
Compression ratio	15/1
Engine rotation	counter clockwise
Idle speed	650
Flywheel	SAE 0
Flywheel housing	SAE 18"

## Customer benefits

**Most advanced Common Rail technology** and high-end injection system (2200 bar), key to achieve strict emissions regulations and competitive performances.

**Highly efficient turbochargers** optimized to operate with high performance keeping fuel consumption under control.

**Individual cylinder heads** allowing easy maintenance.

**Key components** made of highly reliable materials.

## Rated power - Fuel consumption

Duty	kW	HP	RPM	Fuel consumption			IMO	EPA	CCNR	CE97/68
				Optimum value	Rated power					
				g/kWh	g/kWh	l/h				
P1	883	1200	1800	200	202	209	II/III	3/4	II	III A
P2	1030	1400	2100	201	210	254	II/III	3/4	II	III A
P2	1103	1500	2200	200	210	275	II/III	3/4	II	
P3	1214	1650	2300	201	209	311	II/III	3/4	-	-

	P1	P2	P3
Application	Unrestricted Continuous	Heavy	Intermittent
Engine load variations	Very Little To None	Continuous	Important
Average Engine load factor	80-100%	30-80%	50%
Annual working time	More Than 5000 H	3000 -5000 H	1000 - 3000 H
Time at full load	Unlimited	8h Each 12h	2h Each 12h

### P1 Continuous Duty

- Deep sea trawlers
- Shrimps trawlers
- Sea going tug boats
- River tug boats
- Push boats
- Freighters
- Dredges
- LCT
- Ferries

### P2 Heavy Duty

- Deep sea trawlers
- Shrimps trawlers
- Sea going tug boats
- River tug boats
- Push boats
- Freighters
- Dredges
- LCT
- Ferries

### P3 Intermittent Duty

- Seasonal passenger vessels
- Fishing boats
- Pilot boats
- Commercial pleasure boats
- Pump boats
- Displacement sailboats
- Trawlers
- Bow thrusters

### P4 Light Duty

- Private pleasure boats
- Multi-hull pleasure boats
- Survey or rescue fast vessels
- Military fast vessels.

### P5 High performance Duty

- Private pleasure boats
- Multi-hull pleasure boats

## Dimensions and dry weight (mm/kg)

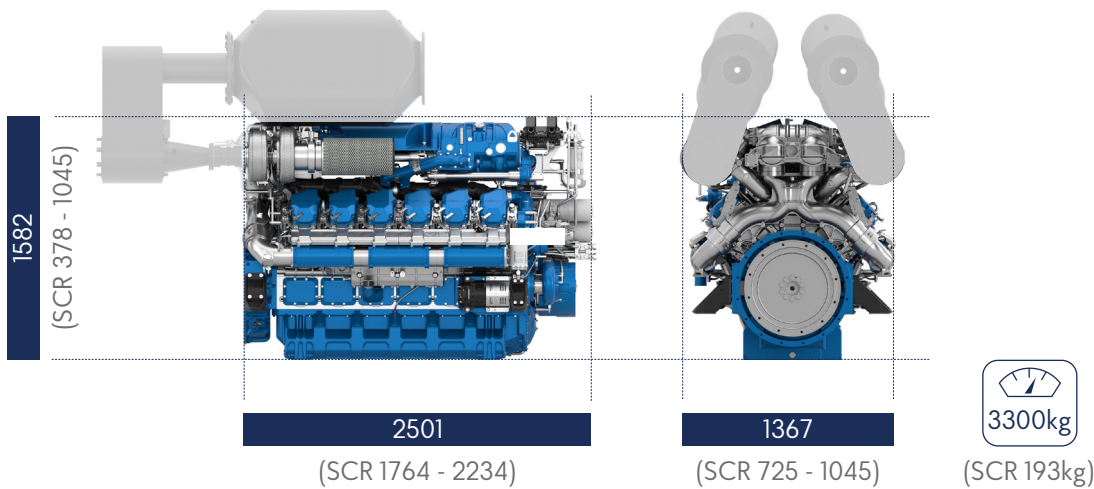

## Standard equipment

### Cooling System

Two - stage cooling circuit with built - in HT thermostatic valve  
 Integrated fresh water expansion tank  
 High efficiency tubular heat exchanger  
 Gear driven centrifugal raw water pump  
 Self priming raw water pump with bronze impeller

### Lubrication System

Full flow lube oil filters duplex type  
 Fresh water cooled lube oil heat exchanger

### Fuel System

Common-rail electronic injection  
 High pressure pump with shielded high pressure injection rail and pipes  
 Fuel oil filter duplex type  
 External fuel pre-filter with water separator

### Intake Air and Exhaust System

Double flow raw water cooled intake air heat exchanger module  
 High efficiency dry turbocharger with ball bearing technology  
 Two Stage Turbocharging system

### Electrical System

Voltage: 24V DC insulated  
 Electrical starter  
 190A battery alternator

### Optional Equipment

Wet exhaust  
 PTO elastic coupling  
 Additional pulley  
 Electric drain system  
 Standard PTO for hydraulic pump  
 Different alternators possible - including 12V  
 Electrical rotary actuator

## Power Curves

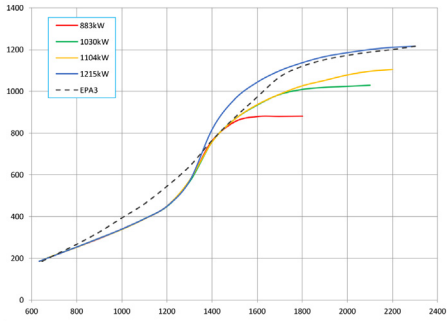

## Torque Curves

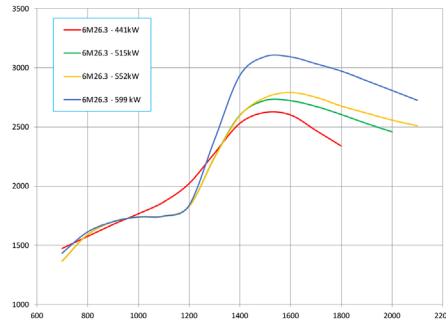

## Cons. Urea - Full Curve

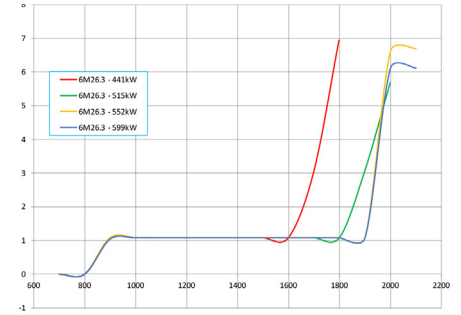

## Full Load

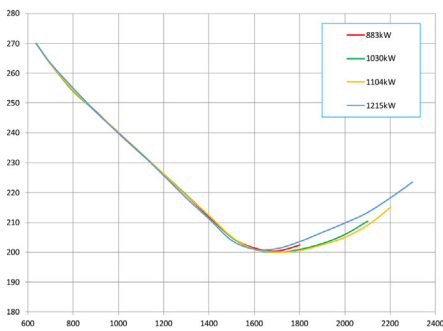

## Prop Curves

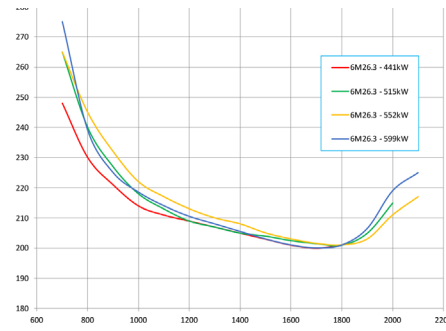

## Power definition

(Standard ISO 3046/1 - 1995 (F))

## Reference conditions

Ambient temperature	25°C / 77°F
Barometric pressure	100 kPa
Relative humidity	30%R
Raw water temperature	25°C / 77°F

## Fuel oil

Relative density	0,840 ± 0,005
Lower calorific power	42 700 kJ/kg
Consumption tolerances	+ 5%
	(DIN ISO 3046-1)
Inlet limit temperature	35°C / 95°F

**Our ratings also comply with classification societies maximum temperature definition without power derating.**

Ambient temperature	45°C / 113°F
Raw water temperature	32°C / 90°F